

SOMERSET

Tel: 978.667.3355

800.772.4404

Fax: 978.671.9466

Email: somerset@smrset.com

www.smrset.com



CDR-170

COMPACT TABLE TOP BREAD MOULDER

IDEAL FOR:

- Breads
- Challah
- Hot Dog Buns
- Specialty Breads
- Dinner Rolls
- Bolillos
- Cuban Bread
- Sub Rolls
- Breadsticks
- Pretzels
- Baguettes

HIGHLIGHTS:

- Makes 30 pcs. per minute, up to 15"
- High volume production
- Consistent products every time
- Easily adjusts for a variety of breads
- Ergonomic design makes it easy to operate and clean
- An ideal machine for limited counter space

Interchangeable pressure plate from 6" to 15"



FEATURES

- Synthetic rollers
- Safety sensors for automatic shutoff
- Compact design, ideal for use in limited space
- Sanitary, heavy duty, all stainless steel welded construction
- Spring loaded scrapers readily removable for easy cleaning
- Simple handle adjustment for uniform products
- Maintenance free drive mechanism, isolated from the roller area
- Easy to operate, easy to clean
- Special pressure plates available to increase machine's versatility
- Easily removable conveyor belt for cleaning and service



Convenient table on casters available

INDUSTRY USES:

- Bakeries • Cafes • Restaurants • Supermarkets • Institutions • Delis • Sub Shops

SPECIFICATIONS

(Specifications subject to change without notice)

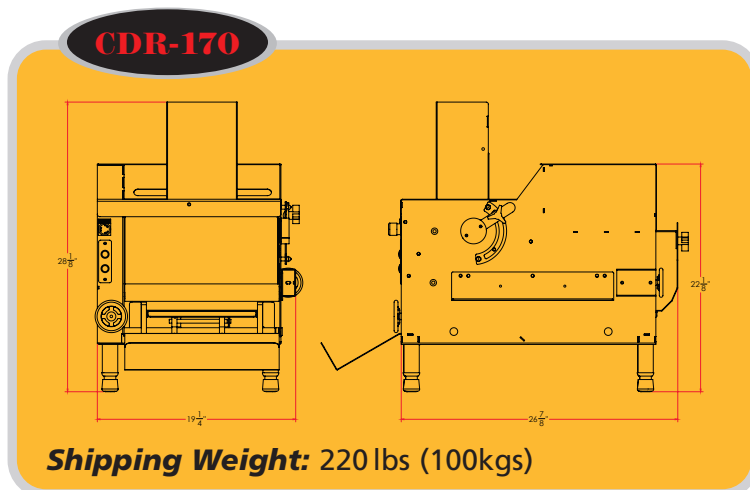

Rollers: 3.5" dia. by 15" length (8.89 cm dia. by 38.10 cm length)

Scrapers: Synthetic, Spring Loaded, Removable

Bearings: Sealed Ball Bearings, Permanently Lubricated

Gear Motor: Heavy Duty 1/2 HP, Maintenance Free, Single Phase, 115v/60Hz, 220v/50Hz

Conveyor Length: 50" (127cm)

Conveyor Belt: 14" (35.50cm)

Pressure Plate: 14" x 24" (35.50cm x 61cm)

Finishing: All Stainless Steel

Shipping Weight: 220 lbs (100kgs)